



SAFETY AND COMFORT



UNIVERSAL LIGHTS AND EQUIPMENT FOR LARGE
AND SMALL COMMERCIAL VEHICLES

FOR SAFETY WORK ENVIRONMENT

HELLA VALUEFIT WORK LIGHTS

- a financially good choice

HELLA ValueFit work lights impress not only because of the many different designs, but also because of their brightness.

- Powerful robust lights with up to 5,500 Lumens.
- Beautiful and elegant design.
- Choose between round, oval, square or flat lamp.



HELLA VALUEFIT WORK LIGHTS

- 12 / 24V
- ECE-R10, CE and RoHS approved.
- Low power consumption
- Standing / hanging mounting



- 9 LEDs
- 1000 Lumen
- 800 mm cable
- Dimensions: 100 x 129 mm

Part Number
357.114-002



- TR1700
- 4 LEDs
 - 1700 Lumen
 - 800 mm cable
 - Dimensions: Ø75 mm

Part Number
357.111-002



- TS1700
- 4 LEDs
 - 1700 Lumen
 - 3000 mm cable
 - Dimensions: 70 x 70 mm

Part Number
357.110-012



- TR3000
- 3000 Lumens
 - 9 LEDs
 - 800 mm cable
 - Dimensions: Ø109 mm

Part Number
357.113-002



- TS3000
- 9 LEDs
 - 3000 Lumens
 - 3000 mm cable
 - Dimensions: 101 x 101 mm

Part Number
357.112-002

HELLA VALUEFIT LED Lightbar work lights

- 12 / 24V
- SAE-approved (LBX 540 LED) and ECE-approved
- IP 67
- Innovative lens design for stealth look.
- Mounting bracket in stainless steel
- Supplied with 2 m cable and DT socket connection



6 LED'S



9 LED'S - SAE APPROVED



12 LED'S

LBX 380 LED	2000 LUMEN - Dimensions: 380 x 86 x 80 mm	Part Number 360.001-002
LBX 540 LED	3500 LUMEN - Dimensions: 540 x 86 x 80 mm	Part Number 360.002-002
LBX 720 LED	5500 LUMEN - Dimensions: 720 x 86 x 80 mm	Part Number 360.003-002

HELLA
VALUEFIT

FOR OFF-ROAD CONDITIONS

More light - extra high beams

Perfect for 4x4, SUV, pickup,
trucks and commercial vehicles.

- 12 / 24V
- Choose between 3 different lengths
- Powerful, homogeneous light effect in modern design.
- Different mounting options



Lightbar LBE 160

- Ref. 12.5
- Dimensions 158 x 73 mm
- 12 / 24V - Power consumption 17W
- Lev. with 0.5 m cable and DT-deutsch connector *

Part Number
358.154-011¹⁾

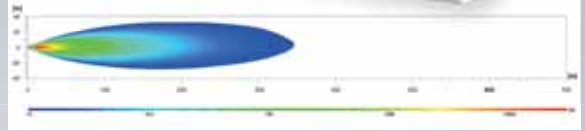

Lightbar LBE 320 with LED position light

- Ref. 30
- Dimensions 311 x 82 mm
- 12 / 24V - Power consumption 48W
- Lev. with 1 m cable and DT-deutsch connector *

Part Number
358.154-001²⁾



Lightbar LBE 480 with LED position light

- Ref. 45
- Dimensions 491 x 82 mm
- 12 / 24V - Power consumption 53W
- Lev. with 1 m cable and DT-deutsch connector

Part Number
358.154-021¹⁾

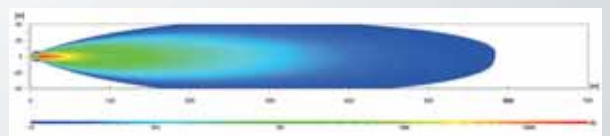

* Additional accessories: 2 m cable with DT-deutsch connector. Part Number 990.299-011

1) 2)

Power Supply 12-36V	Power Supply 12-48V	IP 67	Active Electronic	Polarity Reversal Protection	Over-Voltage Protection	Approval EMC	Approval ECE
------------------------	------------------------	-------	-------------------	------------------------------	-------------------------	-----------------	-----------------

Warning lights

- be seen at jobs in traffic

Wherever a particularly effective visual warning is needed about dangerous situations, it is signal lights that must solve the task.

HELLA signal lights have a strong, warning signal effect on others in traffic. Be careful, show consideration - work nearby of the vehicle.



LED Mini Lightbar 10" and 16"

The powerful LED flash bridges "Micro Lightbar" and "Mini Lightbar" generate an intense 360° warning signal.

- Two sizes - mini and micro
- Can be activated as flash or rotor flash
- Choose between clear / yellow glass
- Three mounting options
Supplied with 0.5 m cable
- Protection against reverse polarity
- Can withstand strong vibrations



	10" Mini Lightbar L25 x B17 cm	16" Mini Lightbar L40 x B22 cm
Fixed, Clear Lens, Amber	014.566-111	014.565-111
Fixed, Amber Lens, Amber	014.566-311	014.565-311
Fixed, Clear Lens, Amber/White	014.566-411	014.565-411
Magnet, Clear Lens, Amber	014.566-121	014.565-121
Magnet, Amber Lens, Amber	014.566-321	014.565-321
Magnet, Clear Lens, Amber/White	014.566-421	014.565-421



Switch with 2 m cable

863.535-001



Rota LED Beacon

- 12 / 24V
- Rotating LED light function
- No moving parts and impact-resistant glass ensures long life
- Power consumption: 10W
- ADR approved

ROTATING FLASH	Dimensions:	
Fixed mounting	H 124 - D 132 mm	010.979-001
Pole mounting	H 183 - D 135 mm	010.979-011
Magnetic mounting	H 126 - D 135 mm	010.979-021



HELLA VALUEFIT SLIM Beacons

- 12 / 24V
- Beacon with slim design in the latest design trend
- Overvoltage and electronics protection
- Approval in accordance with ECE (R10 and R65) and SAE (J845 Class 1)
- Great value for money

Fixed mounting	Dimensions:	
Single and double flash light function	H 50 - D 142 mm	357.980-001
Pole mounting	H 164 - D 142 mm	357.980-011
Double flash		



FOR SAFETY WORK ENVIRONMENT

Warning Lights

- be seen at jobs in traffic

Wherever a particularly effective visual warning is needed about dangerous situations, it is signal lights that must solve the task.

HELLA signal lights have a strong, warning signal effect on others in traffic. Be careful, show consideration - work nearby of the vehicle.



HELLA Nano K-LED flash - "FIT & FORGET"

Compact flash flash as with help of one blink sends a far-reaching, yellow warning signal.

- Multivolt - 12/24 V
- Choose between or Fixed mounting
- Small flash - no space demanding
- Pole mounting with flex rubber base
- Fixed mounting with 3 different mounting options
- Protection against reverse polarity
- Vibration and impact resistant



Fixed mounting	066.146-001
Pole mounting	066.146-011

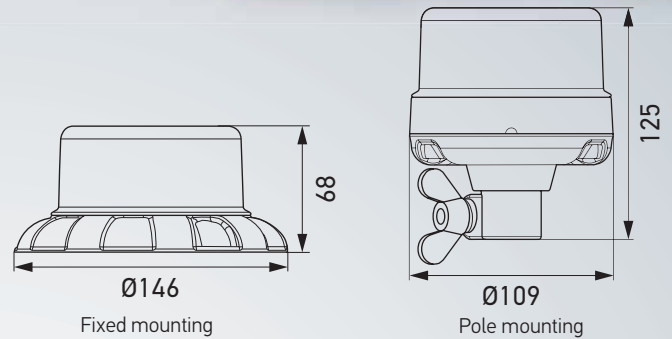

Reflectors - white, yellow or red.

- Round or rectangular
- Mounting with glue or screws
- Round reflector: Ø 6 cm
- Rectangular reflector: H 94 x L 44 mm

	Round - adhesive	Round - screws	Rectangular - adhesive	Rectangular - screws
White	8RA 002 014-291	8RA 002 014-242	8RA 003 326-051	8RA 003 326-021
Yellow	8RA 002 014-301	8RA 002 014-252	8RA 003 326-041	8RA 003 326-011
Red	8RA 002 014-281	8RA 002 014-232	8RA 003 326-031	8RA 003 326-001

Effective warning

- small powerful flashers

Do you occasionally need to make others in the traffic aware of your presence, these small flashes are an economical, easy and good choice.

Elegant design, easy installation and various flash options.



LED warning lights for solder or horizontal mounting

- ECE-R10 / -65 approved
- 12 / 24V
- Different flashing patterns
- Models with "Day / Night mode"
- Flat, compact design allows easy installation.
- Can be synchronized with 2 or more devices
- Clear glass
- Sold as a se



Horizontal Mounting



MS3 MINI LED - Fixed mounting
Dimensions: 85.6 x 28 x 16 mm
Part Number
358.111-221 (Amber)
358.111-241 (White)



MS6 Strobe Lighthead
Fixed mounting
Dimensions: 128 x 28 x 17 mm

Part Number
358.111-151 (Amber)
358.111-161 (White)
358.111-171 (Blue)
358.111-181 (Red)
358.111.191 (Amber/White)
358.111.201 (Red/Blue)
358.111.211 (Red/White)



MS6-DC DUAL COLOR
Fixed mounting
Dimensions: 130 x 25 x 18 mm
Part Number
358.118-131 (Red+Blue split w/ All White overwrite function)
358.118.141 (Amber+White split w/ All White overwrite function)
358.118-151 (All Red /All Blue overwrite)
358.118-161 (All Red/All White overwrite)
358.118.171 (All Blue/All White overwrite)

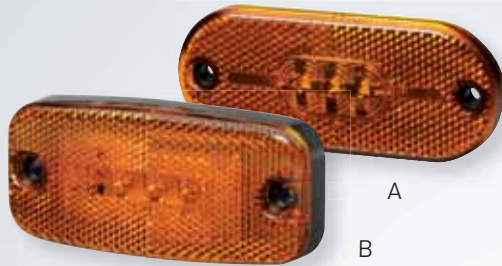

A
B

Amber LED side marker light without holder with reflex.

A - 12V - with 3 LED's	357.009-001
B - 12/24V - with 3 LED's	357.008-001

Flat flashing lights - 12 / 24V 2 models with 3 or 6 LEDs for flush mounting.

- Low power consumption: 8 W
- Clear glass with orange light when activated
- 12 or 23 integrated programmable flash sequences upon activation
- Programmable synchronous / shifting sequences by connecting several lamps
- Aluminum base plate and LED longlife technology provide service life of up to 100,000 operating hours
- Totally waterproof and vibration-resistant
- EMC radio noise canceling (ECE R10)
- California Title 13, SAE J595 Class 1
- E-Approved (R65 using single flash)
- IP 67



MST3 Slim Strobe
With 3 LED's - 88 MM

358.111-001 (Amber)
358.111-011 (Blue)
358.117-131 (White)
358.117-121 (Red)

MST6 Slim Strobe
With 6 LED's - 130 MM

358.111-321 (Amber)
358.111-331 (Blue)
358.111-341 (White)
358.111-351 (Red)
358.111-361 (Amber/White)
358.111-371 (Red/Blue)



Vehicle Specific Lighting

- OE replacement.

We offer a wide range of products covering all aspects of vehicle lighting, from headlamps and combination rear lamps to signal lamps, interior lamps and lighting electronics. Our development activities currently focus on features and technologies expected to be especially important in the future, generating benefits that customers can see and touch, such as light-based driver assistance systems, LEDs and design elements.



Find all vehicle applications in the following link:



<https://hella.mypartfinder.com/>

Light Commercial Vehicle Applications (extract)



MERCEDES-BENZ SPRINTER

Headlight Assembly	247012091	Left	2010-2012	Headlamps Halogen
Headlight Assembly	247012101	Right	2010-2012	Headlamps Halogen
Headlight Assembly	247012251	Left	2010-2012	Headlamps Xenon
Headlight Assembly	247012261	Right	2010-2012	Headlamps Xenon
Headlight Assembly	011030151	Left	2014-2014	Headlamps Halogen
Headlight Assembly	011030161	Right	2014-2014	Headlamps Halogen
Tail Light Assembly	013252231	Left	2019-2020	Bulb - Sprinter 1500 Sprinter 2500 Sprinter 3500
Tail Light Assembly	013252241	Right	2019-2020	Bulb - Sprinter 1500 Sprinter 2500 Sprinter 3500
Tail Light Assembly	013253231	Left	2019-2020	Hybrid - Sprinter 1500 Sprinter 2500 Sprinter 3500
Tail Light Assembly	013253241	Right	2019-2020	Hybrid - Sprinter 1500 Sprinter 2500 Sprinter 3500
Fog Light Assembly	011250331	Left	2014-2016	Sprinter 2500 Sprinter 3500
Fog Light Assembly	011250341	Right	2014-2016	Sprinter 2500 Sprinter 3500



MERCEDES-BENZ METRIS

Headlight Assembly	011284551	Front Left	2016-2016	Metris
Headlight Assembly	011284561	Front Right	2016-2016	Metris
Headlight Assembly	011284851	Front Left	2016-2017	Metris
Headlight Assembly	011284861	Front Right	2016-2017	Metris
Tail Light Assembly	011581311	Left	2016-2019	Metris
Tail Light Assembly	011581321	Right	2016-2019	Metris
Tail Light Assembly	011581331	Left	2016-2019	Metris
Tail Light Assembly	011581341	Right	2016-2019	Metris
Tail Light	011581311	Left	2013-2020	Metris Vito
Tail Light	011581321	Right	2013-2020	Metris Vito



Acoustic Unit Signals

- safety above all

HELLA's horns, trumpet horns, and air trumpet horns are designed and manufactured with German precision technology. We work with world-class vehicle manufacturers so you can rest assured that your horns feature state-of-the-art and the best technologies. HELLA quality isn't just seen, it's also heard: our specialized experience in developing horns and air trumpet horns complies with strict ECE and OEM requirements, both in applications for passenger cars and commercial vehicles



Product image / Dimensions	Features
----------------------------	----------



TE16 Series - Set of Twin Tone Trumpet Horns with 12 V Relay

ABS plastic housing and black bracket in galvanized metal.
 Level of acoustic intensity at 2 m distance: 110 dB(A).
 Energy consumption: 2 x 72 W.
 M8 screw horn bracket.
 Operating Temperature: -40° C a 90° C (-40°F a 194°F)
 With flat connections of 6.3 mm, open, blade type
 Approval: ECE R28
 Includes 12 V Relay



2 Pieces
1 Relay

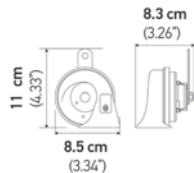

Part Number	Quantity	Description
007424801	2 Pieces	Trumpets 12 V, 2 x 72 W, 400 / 500 Hz - Universal Diameter Measurements: 8.1 cm 8 x 10.9 cm Red Horn
	1 Piece	Includes 12 V Relay



TC16 Series

ABS plastic housing and galvanized metal bracket
 Level of acoustic intensity at 2 m distance: 113 dB(A).
 Energy consumption: 2 x 72 W.
 M8 screw horn bracket.
 Operating Temperature: -40° C a 90° C (-40°F a 194°F)
 With flat connections of 6.3 mm, open, blade type
 Approval: CCC



2 Pieces



2 Pieces

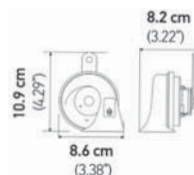

Part Number	Quantity	Description
011225831	2 Pieces	Box (graphic) Trumpets 12 V, 2 x 72 W, 400 / 500 Hz - Universal Diameter Measurements: 8.6 cm 8.6 x 10.9 cm
012010971	2 Pieces	Plastic blister Horn 12 V, 2 x 72 W, 400 / 500 Hz - Universal Diameter Measurements: 8.6 cm 8.6 x 10.9 cm

Product image /
Dimensions

Features



2 Pieces
1 Relay



1 Piece



2 Pieces
1 Relay

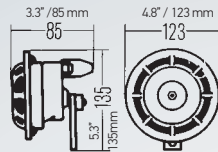

B133 Series - Supertone Horns with 12 V Relay



Extremely concentrated sound radiation and powerful range. Particularly suitable for traffic on motorways.



Black housing, diaphragm and bracket, red protective grille, in galvanized metal.

Level of acoustic intensity at 2 m distance: 118 dB(A).

Energy consumption: 2 x 66 W

M8 screw horn bracket.

Operating Temperature: -40° C a 90° C (-40°F a 194°F)

With flat connections of 6.3 mm, open, blade type

Approval: ECE R28

Part Number	Quantity	Description
003399901	2 Pieces	Plastic blister Horns 12 V, 2 x 66 W, 300/500 Hz - Universal Diameter Measurements: 12.3 cm 8.5 x 12.5 cm
	1 Piece	Includes 12 V Relay
003399801	2 Pieces	Box (graphic) Horns 12 V, 2 x 66 W, 300/500 Hz - Universal Diameter Measurements: 12.3 cm 8.5 x 12.5 cm
	1 Piece	Includes 12 V Relay
358114051	1 Piece	High Tone - Box (yellow) Horn 12 V, 1 x 66 W, 500 Hz - Universal Diameter Measurements: 12.3 cm 8.5 x 12.5 cm



With grounding strap



1 Piece



1 Piece



Backup Alarm



Black plastic housing.

With integrated bracket for universal mounting.

The level of sound intensity is generated by the electronics of solid bodies.

Level of acoustic intensity at 2 m distance: 110 dB (A).

Multivoltage: 9 V - 48 V

Rated Continuous Current: 0.1 - 0.6 A

Operating temperature: -40 ° C to +85 ° C.

Protection class: IP67 (Resistant to water immersions)

Approval: ECE R10 / 107 dB



Part Number	Quantity	Description
009148142	1 Piece	Backup Alarm - Plastic blister Multivolt: 9 - 48 V - Universal Protection Class: IP67K Measurements: 10.1 x 3.9 x 6.5 cm
009148141	1 Piece	Backup Alarm - Box Multivolt: 9 - 48 V - Universal Protection Class: IP67K Measurements: 10.1 x 3.9 x 6.5 cm
009148161	1 Piece	Backup Alarm - Box - with grounding strap Multivolt: 9 - 48 V - Universal Protection Class: IP67K Measurements: 10.1 x 3.9 x 6.5 cm
009148221	1 Piece	Backup Alarm - Box - with grounding strap, SAE J994 Type C, 102 dB (A) Multivolt: 9 - 48 V - Universal Protection Class: IP67K Measurements: 10.1 x 3.9 x 6.5 cm

Ask your sales representative
about product availability in your region



BRAKE SYSTEMS

Light commercial range

The new Hella Pagid Light Commercial range has been designed to leverage OE Brake competence with unique market experience to provide the best possible brake combination for your customers light commercial vehicles. Starting with increased stopping power from European produced pads and finishing off with High Carbon rotors to dissipate heat to allow optimum braking and increased longevity.

Find all vehicle applications in the following link:



<https://hella.mypartfinder.com/>

- European stopping power for light commercial applications
- High Carbon Rotors Designed to absorb and dissipate heat more effectively than iron rotors
- European Wear Sensor Program
- Heavy Duty Police and Taxi Pads
- OE quality



Light Commercial Vehicle Applications (extract)



FORD TRANSIT CONNECT

Brake Pad	355009561	Front	2010-2020	Transit Connect
Brake Rotor	355300431	Rear	2010-2013	Transit Connect
Brake Rotor	355110291	Rear	2014-2016	Transit Connect
Brake Rotor	355110282	Front	2010-2013	Transit Connect



FORD TRANSIT

Brake Pad	355021571	Front	2015-2020	Transit-150 Transit-250 Transit-350 Transit-350 HD
Brake Pad	355020721	Rear	2015-2018	Transit-150 Transit-250 Transit-350 Transit-350 HD
Brake Rotor	355123131	Front	2015-2016	Transit-150 Transit-250 Transit-350 Transit-350 HD
Brake Rotor	355122781	Rear	2015-2016	Transit-150 Transit-250 Transit-350
Brake Rotor	355120181	Rear	2015-2016	Transit-150 Transit-250 Transit-350
Wear Sensor	355252591	Rear	2015-2015	Transit-150 Transit-250 Transit-350

Light Commercial Vehicle Applications (extract)



MERCEDES-BENZ SPRINTER

Brake Pad	355005531	Front	2010-2020	Sprinter 1500 Sprinter 2500 Sprinter 3500 Sprinter 3500XD Sprinter 4500
Brake Pad	355005351	Rear	2010-2018	Sprinter 2500
Brake Pad	355014401	Rear	2013-2014	Sprinter 2500 Sprinter 3500
Brake Pad	355050761	Rear	2010-2012	Sprinter 2500 Sprinter 3500
Brake Pad	355005541	Rear	2010-2018	Sprinter 3500 Sprinter 3500XD
Brake Rotor	355123162	Front	2010-2018	Sprinter 2500 Sprinter 3500 Sprinter 3500XD
Brake Rotor	355123172	Rear	2010-2018	Sprinter 2500
Brake Rotor	355123182	Rear	2010-2020	Sprinter 3500 Sprinter 3500XD Sprinter 4500
Brake Rotor	355131831	Rear	2019-2020	Sprinter 1500 Sprinter 2500
Wear Sensor	355250771	Front	2010-2020	Sprinter 1500 Sprinter 2500 Sprinter 3500 Sprinter 3500XD Sprinter 4500
Wear Sensor	355250761	Rear	2010-2020	Sprinter 1500 Sprinter 2500
Wear Sensor	355250961	Rear	2010-2018	Sprinter 3500 Sprinter 3500XD
Disc Brake Caliper	355787291	Front Left	2010-2018	Sprinter 2500
Disc Brake Caliper	355787301	Front Right	2010-2018	Sprinter 2500



MERCEDES-BENZ METRIS

Brake Pad	355021761	Rear	2016-2020	Metris
Brake Pad	355005521	Front	2010-2020	Metris Sprinter 2500
Brake Rotor	355122441	Rear	2016-2020	Metris
Brake Rotor	355110071	Front	2016-2020	Metris
Wear Sensor	355250771	Front	2010-2020	Metris



NISSAN NV200

Brake Pad	355016121	Front	2011-2019	NV200
-----------	-----------	-------	-----------	-------



RAM PROMASTER

Brake Pad	355021901	Rear	2014-2020	ProMaster 1500 ProMaster 2500 ProMaster 3500
Brake Pad	355021281	Front	2014-2016	ProMaster 1500
Brake Pad	355023011	Front	2014-2016	ProMaster 2500 ProMaster 3500
Brake Pad	355019901	Front	2015-2018	ProMaster 1500 ProMaster 2500 ProMaster 3500
Brake Rotor	355125261	Front	2014-2019	ProMaster 1500 ProMaster 2500 ProMaster 3500
Brake Rotor	355113731	Rear	2014-2016	ProMaster 2500 ProMaster 3500



EVERYTHING WE DO REVOLVES AROUND OUR CUSTOMERS

In order to ensure that business runs smoothly, HELLA supports wholesalers as your daily business is already complicated enough. That's why we see it as our job to make this as simple as possible for you.

For the aftermarket, we offer outstanding availability of goods using sophisticated logistics and first-class data management as well as targeted sales support. This speeds up and simplifies the wholesale business – for greater efficiency.

We support workshops throughout the entire repair process. We search proactively for new solutions to help independent workshops successfully master the growing complexity of the different models so that customer cars can „hit the road“ that much faster. This is how we make your daily business run faster and more profitable.

OUR SUPPORT FOR YOU AND YOUR CUSTOMERS



www.hella.com/techworld



www.hella.com/partnerworld/

HELLA TECH WORLD

- Online platform for workshops
- Vehicle-specific repair Information
- Technical information
- Technical videos
- Responsive design

HELLA PARTNER WORLD

- Online portal for wholesalers
- Monthly list of new products for download
- Compact information about all highlight products
- Marketing support



HELLA Automotive Sales, Inc.

201 Kelly Drive
Peachtree City, GA, 30269
Tel.: +1 (877) 224-3552
Fax: +1 (770) 631-7574
www.myhellalights.com

HELLAMEX, S.A. de C.V.

Carretera México Querétaro Km 30,
Bodega 2B
San Martín Obispo, Cuautitlán Izcalli,
Edo. de México. C.P. 54763
Tel. Ventas: +52 (55) 5321-1380 / 1001
Servicio Técnico: 01 800 221-0471
hellamex@hella.com
www.hellamex.com

HELLA do Brasil Automotive Ltda.

Rua Bom Pastor, 2224 - 15º andar São
Paulo, SP
04203-002 Brasil
Telefone: +55 (11) 2627-7800
info.brasil@hella.com
www.hella-brasil.com

© HELLA KGaA Hueck & Co. Lippstadt
999.143-032 08.2022
Printed in USA